

Orkney

FISHING BOATS 

DAY ANGLER 19+

CONSTRUCTION

Hull, deck and ancillary mouldings are constructed in heavy duty hand lay-up GRP. Isophthalic resin is used in the hull which is stiffened below the waterline by bonded-in bulkheads and longitudinal stringers. The main underfloor areas are foamed and the cockpit is self-draining. Above the waterline the hull is stiffened by ribs in the cockpit area and by a GRP module in the cabin. The one piece deck moulding is fixed to the hull with marine grade fastenings.

HULL AND DECK FITTINGS

Stainless steel winch eye, galvanised keel and bilge keel bands. Anodised alloy bow roller, mooring cleat and stern cleats. Stainless steel handrails from wheelhouse to foredeck. Toughened glass windows to front and side of wheelhouse with single perspex window in bulkhead aft of steering position. Fitted bilge pump, Push/pull steering to suit through pivot steering outboards (Note: Standard steering cable suits single outboard installation for twin engines consult your dealer).

ACCOMMODATION

Enclosed cuddy/cabin with 2 berths/bench seats and stowage lockers under. Wheel steering to starboard. Helmsman and co pilot's seats with cushions. Lockable cabin door.

PART BUILT BOATS

We have always offered our fishing boats as mouldings to professional and amateur boat builders for completion to their own specifications. These mouldings can be supplied at any stage from bare hull shells upwards. We are pleased to quote for the supply of additional items from our range of components and fittings.

COLOURS

Hull: Dark blue

Deck: Off white Special colours available at extra cost.

DELIVERY CHARGES

Prices quoted for standard and part built boats and mouldings include the cost of delivery from our works to our approved point of sale dealers on the UK Mainland only. Delivery may be charged for urgent orders or for accessories and trailers ordered and/or delivered separately, and for boats delivered outside the UK Mainland.



DAY ANGLER 19+

LOA	19'6"	5.95 m
Beam	7'6"	2.29 m
Weight	1650 lbs	750 kg
Engine options	Single or Twin Outboard	
Max power	65 HP	
Max speed	23 knots	
Optimum speed	15 knots	
Performance indicator	30 HP	12 knots
(Estimated)	50 HP	17 knots
	65 HP	23 knots

Average cockpit dimensions
6'10" x 6'2" = 42 sq ft
2.09m x 1.88 m = 3.82 sq m

General Arrangement showing optional pulpit, mast navigation lights and windows in aft bulkhead.

TT BOAT DESIGNS

The all new Day Angler 19+ is the result of design collaboration between Orkney and TT Boat Designs: TT are best known for their Nelson launches and Pilot boats. Nelsons are used by many of the world's harbour and port authorities for year round operation in all conditions: Inevitably the new 19 displays excellent sea keeping ability which together with the big working cockpit and sheltered helm position make it ideal for both the sea angler and commercial user.

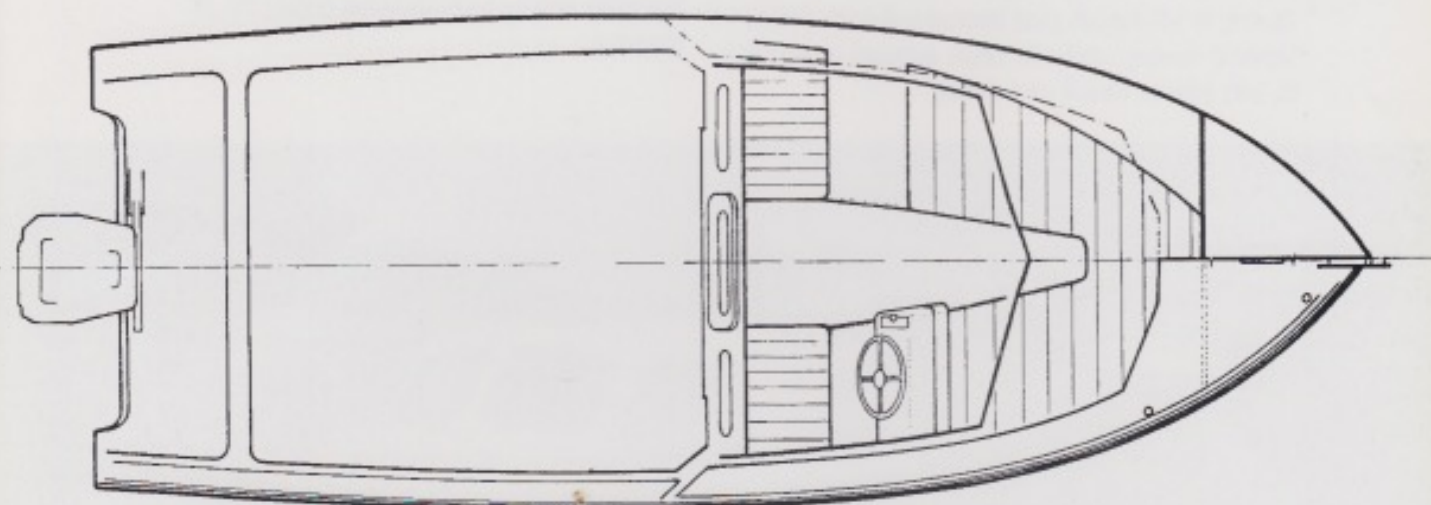
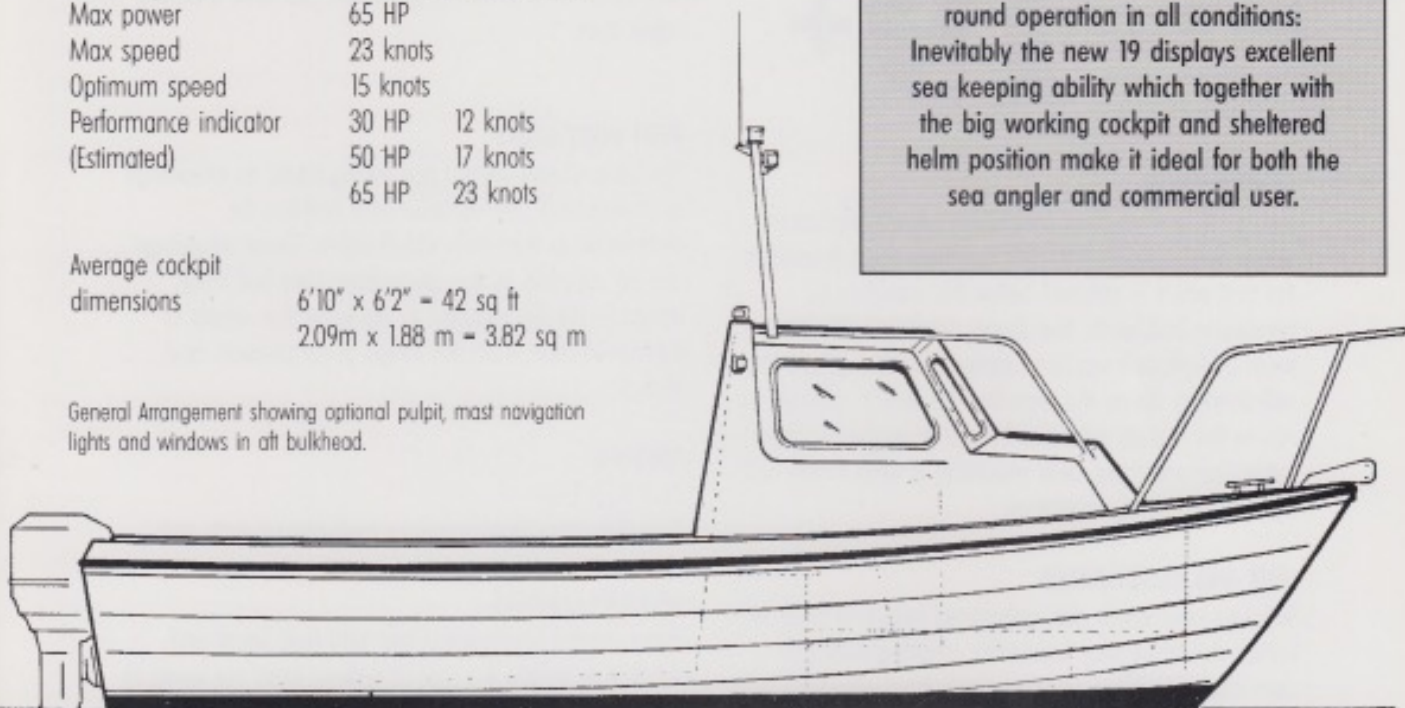

Orkney Boats Ltd, Ford Lane Industrial Estate,
Yapton, Arundel, Sussex BN18 0DF
Telephone: 01243 551456 Fax: 01243 551914

Please note that performance indicators are approximate, dependant on payload and not guaranteed. Lengths quoted are hull lengths only and other data is for general guidance. All weights and measurements are approximate. Drawings may show boats fitted with optional equipment. If your application is unusual or particularly arduous please consult us or your dealer to ensure that you get the right boat for the job.

TERMS OF BUSINESS: A copy of our Terms of Business is available on request. E & OE